

RF

By Zack Lau, W1VT

A Small 70-cm Yagi

This six-element Yagi was designed for a wide bandwidth—in gain, F/B and SWR. Joe Riesert, W1JR, measured its gain at 8.5 dBd during the 1995 Eastern States VHF/UHF Conference—with little gain variation between 417 and 446 MHz.¹ The SWR is almost as broad, with better than 1.4 SWR between 422 and 446 MHz. The gain and return loss curves measured by Joe's HP 8753C are shown in Fig 1. The short 30-inch boom is small enough to fit in the trunk of a compact sedan, perfect for portable or emergency work. The F/B bandwidth is also very good, with over 20 dB of F/B between 424 and 450 MHz, according to a *Yagi Analyzer* computer model.² *Yagi Analyzer* predicts a gain between 8.51 and 9.45 dBd between 417 and 446 MHz.³ Even if you only intend to use this antenna on 432-MHz SSB or 436-MHz satellite, the extra bandwidth is useful when it rains. Heavy rain causes antenna elements to resonate lower in frequency. This is much worse if the antenna is tweaked for maximum gain. Yagis typically have a low-pass gain response. The gain falls off rapidly past the maximum-gain point. Thus, while the maximum gain is around 442 MHz, the gain is significantly lower at 457 MHz, while only a little bit lower at 427 MHz.

Electrical Design

Rather than start from scratch, I began the design optimization using an existing HF antenna design and scaled it up to 446 MHz. HF antennas tend to be very well optimized by serious contesters. Their designs make good starting points if you want to build an antenna with fewer than 10 elements.^{4, 5} I then decided to trade

some gain for bandwidth. The beam is already small enough that there really isn't much of an advantage to squeezing out as much gain as possible for a given boom length. This is different

from other designs. Usually you want as much gain as possible from a given boom length. The optimized design is shown in Fig 2. The element lengths are adjusted to work with a particular

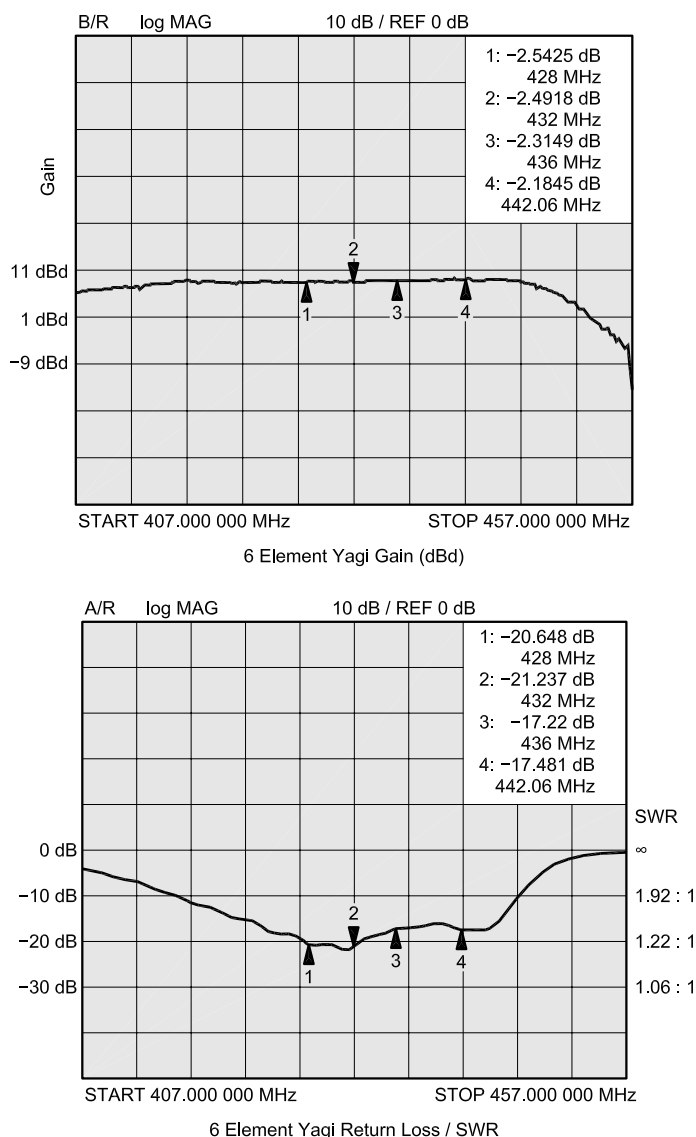

Fig 1—Gain and SWR measurements for the 70-cm Yagi.

¹Notes appear on page 59.

boom and mounting arrangement. Changing the boom or element mounting may require adjusting the element lengths. I decided to use a simple T-match, as simpler gamma matches have a poor reputation on this band. A T-matched Yagi is more likely to have a symmetrical radiation pattern.

The feed system shown in Fig 3 is a copy of that used in the K2RIW Yagi. A half-wave balun made out of semi-rigid coax steps up the impedance to 200 Ω. Similarly, the T match steps up the impedance of the driven element to 200 Ω. UT-141A semi-rigid coax has become easy to obtain. You can now find it at any big hamfest. The preferred material for holding the balun to the boom is a black nylon cable clamp. White nylon is less UV resistant, while a metal clamp presents a galvanic corrosion problem with either the copper jacket of the coax or the aluminum of the boom. I recommend tilting the coax connector away from the boom. This makes it easier to attach the N connector. A UHF connector is not recommended at 70 cm. The matching network would have to be redesigned to tune out the impedance mismatch created by connector. The drilling layout for the mounting bracket is shown in Fig 4. After bending it into an L, I bent it with a pair of pliers to match the boom. This isn't necessary and looks quite a bit worse than the nicely formed brackets that were once sold by Tom Rutland of Rutland Arrays.⁶ Aluminum alloy (5052-H32) is a good choice for the mounting bracket, as well as any other corrosion-resistant sheet-metal parts that need to be bent.

The copper straps (see Fig 5) for the balun are bent with round-nosed pliers to form a curve that matches the semi-rigid coax shield. Once the straps are soldered to the balun, I wrap copper foil around the soldered joint for reinforcement and solder the assembly again. The finished assembly is

considerably more rugged. If you use a square boom, the two copper straps that hold the semi-rigid coax may be replaced by a single U-shaped strap sandwiched between the boom and mounting bracket. In that case, I'd recommend tinning the copper strap with solder to reduce the difference in electromotive potentials between the metals that result in galvanic corrosion. Similarly, brass rod or tubing can be used for the driven element to reduce the corrosion problem. I used 3/16-inch 6061-T6 aluminum rod for the elements of the prototype.

Mechanical Design

The mechanical design is based on

work by Dick, K2RIW, and George, W2KRM. Dick discovered that Yagis with through-the-boom-mounted elements would lose gain due to aluminum oxide changing the effective electrical lengths. Some of the elements would become insulated from the boom, becoming longer electrically. For a one-inch diameter boom, this is a variation of about 0.3 inches, which is quite significant on 70 cm. Fire up a computer model and see what happens when you add 0.3 inches randomly to a few elements. As documented in *The ARRL Antenna Book*, Dick mounted his elements on plastic blocks riveted to the boom.⁷ After creating RIW Products in 1977, George, W2KRM, de-

Table 1—Yagi Analyzer Model with Spacings between Elements and Half-Element Lengths

file	446.yag
446	6 el
432.000	446.000 446.000 MHz
6	elements, inches
Spacing	0.188
0.000	6.798
2.394	5.866
2.715	6.024
6.528	5.836
7.907	5.787
7.546	5.390

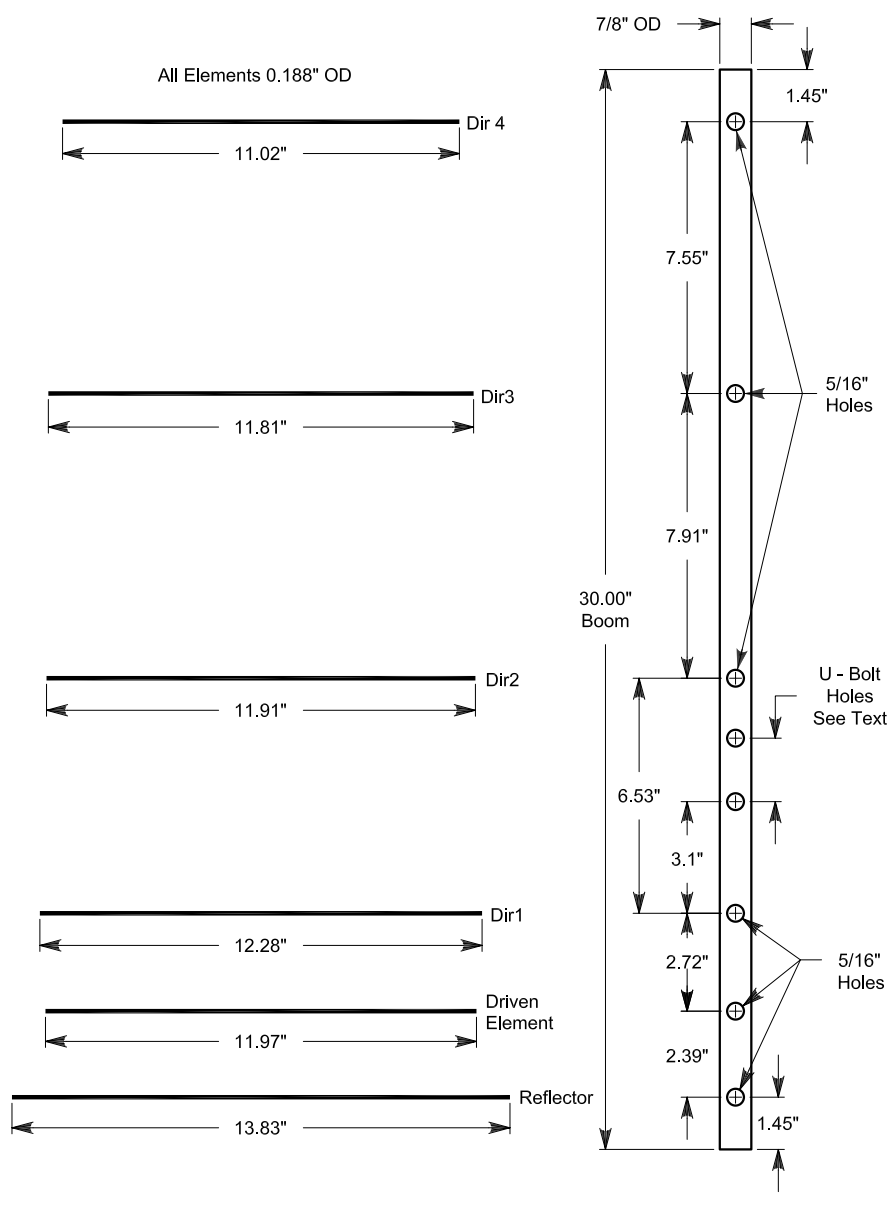

Fig 2—Rough scale drawing of the boom and elements.

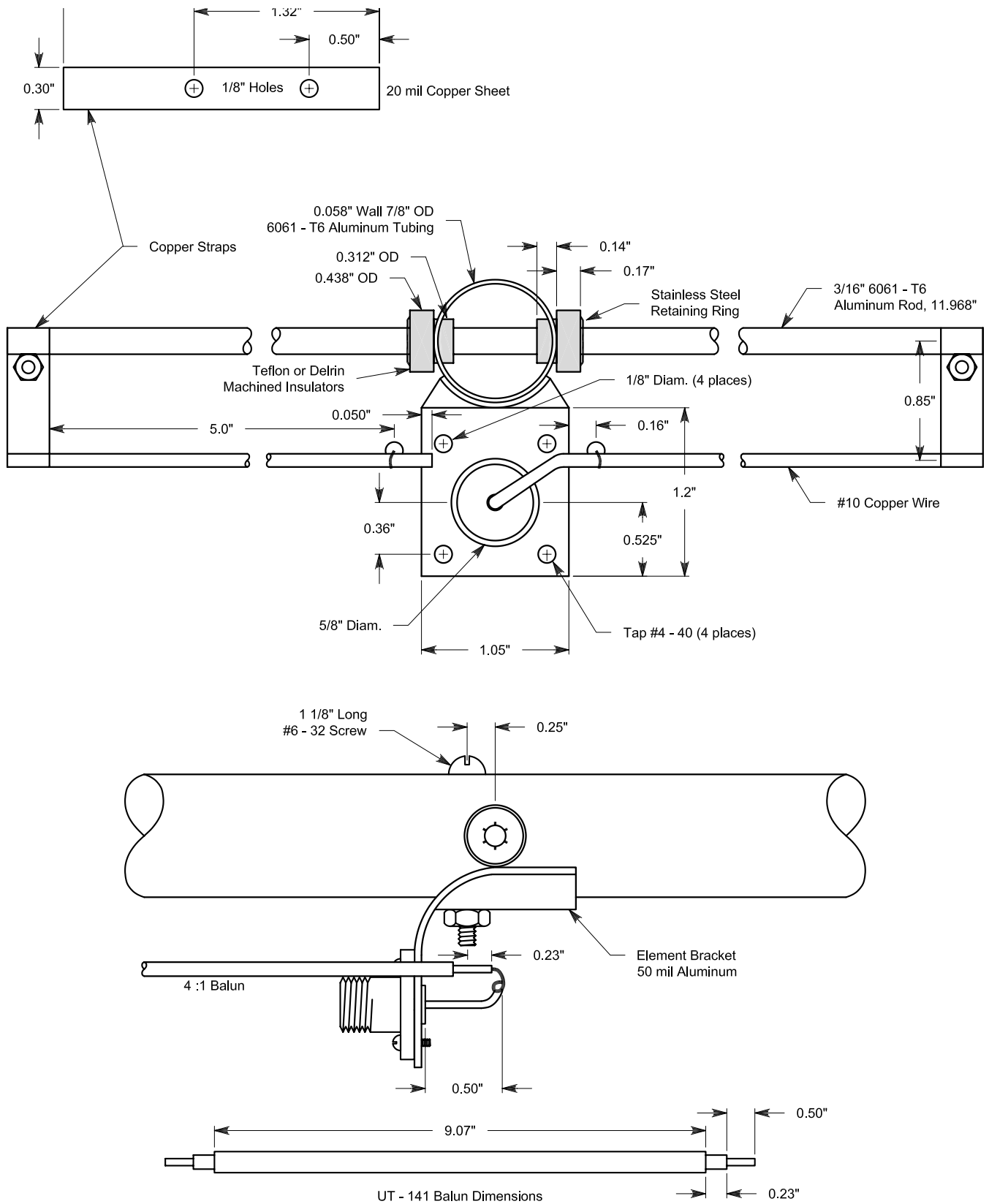

Fig 3—Yagi feed system. The balun is held to the boom with a 1/8-inch black nylon clamp. I'd suggest a Digi-Key #RP323 or Richco Plastic Co N-2-BK.

vised the method with UV protected Delrin shoulder washers and push on fasteners for quick assembly. The commercial version of the RIW-19 was reviewed in *QST* (Dec 1978, p 34).

I used stainless-steel retaining rings and shoulder washers to securely attach the elements through a 7/8-inch round aluminum boom. At 70 cm, a 0.236-inch boom correction is required when using insulated elements mounted through the boom. Each element needs to be 0.236 inches longer than the free-space length. This results in the element lengths shown in Table 2. These lengths will also work with a 7/8-inch square boom. Significantly changing the mounting technique or boom diameter may result in the need for a different boom correction. Chapter 9 of *The ARRL UHF/Microwave Experimenter's Manual* is an excellent reference on boom corrections. The spacings are between element centers. I like to use aluminum booms, as they are strong and light. The shoulder washers

shown in Fig 6 are easy to make if you have a lathe.⁸ A 7/16-inch Delrin rod is drilled to accept the 3/16-inch-diameter elements. A lathe is used to cut the 5/16-inch shanks. A cutoff tool is then used to quickly separate the finished shoulder washers. A rear-mount cutoff tool can be used for quickly alternating between the tool bit and the cutoff tool. A miniature hobby lathe should work just fine when working with small pieces of plastic. While normally not necessary, you can use Teflon for more UV resistance. Cheap SB-313 black nylon insulators sold by Heyco will also perform adequately. While nylon isn't a great RF insulation material, that quality isn't required for this application.

Before drilling the boom, I recommend measuring the U-bolt used for mounting the mast to determine dimension "U." I've found that the actual spacing can vary just a bit. Apparently the fabrication technique for bending U-bolts isn't as precise as other machining operations. The spacing on the pro-

tototype is 2 inches. I find that 5/16-inch holes seem to work okay, although 1/4-inch holes would work better if drilled accurately. I use wing nuts to attach the U-bolt to a mast. I've found a machined saddle that precisely matches the curvature of the boom tremendously reduces slippage when tools are not available for assembly.

Commercial 432-MHz antennas often use standoff insulators to mount the T-bars. I have not found this necessary for portable work. While the bars do slowly become unsoldered with rugged handling, it is a simple matter to resolder the bars. It also helps to wrap the center conductor of the semi-rigid coax around the T-bars to make a good mechanical connection.

Figs 7 and 8 show the completed antenna. There's a close up of the feed-point area on the cover of this issue.

Alternative Yagi Designs

If you need something simpler, I recommend the "Cheap Antennas," by Kent Britain, WA5VJB.⁹ They have

Table 2—Actual Yagi Element Lengths and Spacings between Element Centers

Spacing	Cumulative Boom Length	Element Length
0		13.832
2.394	2.394	11.968
2.715	5.109	12.284
6.528	11.637	11.908
7.907	19.544	11.810
7.546	27.09	11.016

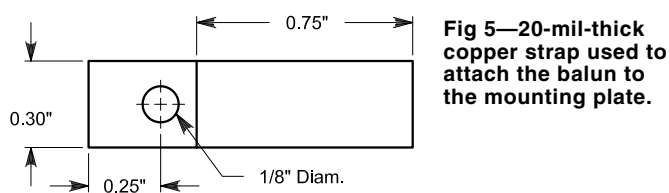

Fig 5—20-mil-thick copper strap used to attach the balun to the mounting plate.

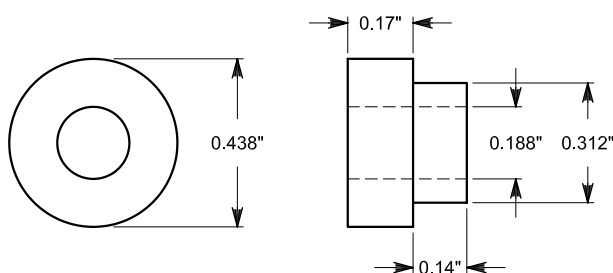

Fig 6—Delrin shoulder-washer dimensions.

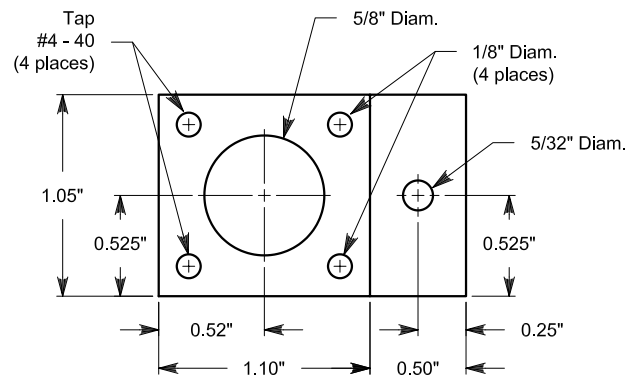

Fig 4—Mounting bracket dimensions (before bending). I recommend 50-mil thick 5052-H32 aluminum.

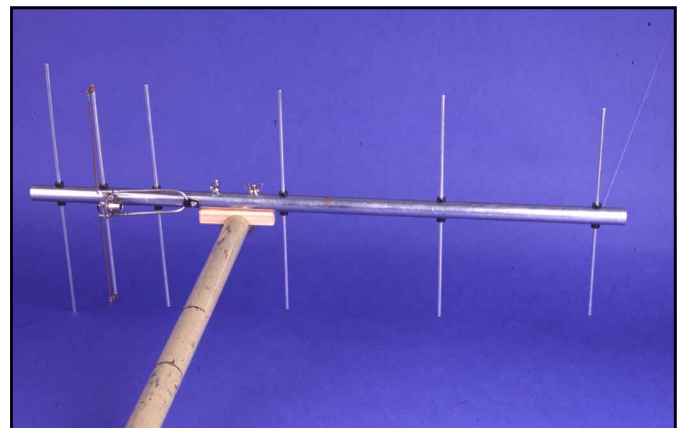

Fig 7—70-cm Yagi mounted to a 1/4-inch boom.



Fig 8—Yagi showing reflector, driven element and first director.

wooden booms and a very simple feed system. Kent presents four different designs to cover the 70-cm band. His designs are optimized for 421.25, 432, 435 and 450 MHz. Kent reinvented a very simple J-shaped feed that appeared in *Understanding Amateur Radio*.¹⁰ The first antenna with a J-shaped feed was a three-element 2-meter beam. Alternately, if you want a little more gain, I've had good luck with Steve's 10-element, 14-dBi 432-MHz Yagi that fits on a 62-inch boom.¹¹

Notes

¹The reference antenna was a 11-dBd Antennaco Yagi that has 10 elements on a 5-foot boom.

²A Windows compatible version of this program comes on a CD with the 19th edition of *The ARRL Antenna Book* (Newington: ARRL, 2000, Order No 8047).

³YA uses isotropic gain -2.15 dB as dBd.

⁴D. Leeson, W6QHS, *Physical Design of Yagi Antennas*, (ARRL, 1992, Order No 3819).

⁵R. Straw, N6BV, *The ARRL Antenna Book*, 19th edition.

⁶Thomas H. Rutland, K3IPW, SK.

⁷*The ARRL Antenna Book*, 13th Edition (ARRL, 1974), pp 243-244.

⁸Machined shoulder washers are also available from Byer's Chassis, Directive Systems and Down East Microwave.

⁹K. Britain, WA5VJB, "Cheap Antennas," *Proceedings of the 28th Conference of the Central States VHF Society*, (ARRL, 1994,

Order No. 4823) pp 58-63.

¹⁰George Grammer, *Understanding Amateur Radio*, (ARRL, 1963), p 293.

¹¹Steve Powlisken, K1FO, "Rear-Mount Yagi Arrays for 432-MHz EME: Solving the EME Polarization Problem," *The ARRL Antenna Compendium*, Vol 3, (ARRL, 1992, Order No 4017), p 8. □



ACTIVE

ELECTRONIC COMPONENTS DEPOT

OVER 115,000 ELECTRONIC COMPONENTS AVAILABLE!

More than 5,000 products on display!

Active has the widest selection of the latest electronics and production supplies, all in a local, easy-to-shop store near you.

Serving the electronic needs of engineers, technicians, hobbyists, MRO and students for over 30 years.



- Electronic Components
- Test & Measure Equipment
- Soldering Equipment
- Semiconductors
- Wire and Cable
- Chemicals
- Passive Components
- Hand Tools
- Books and much more!

Visit an Active Store near you!

<p>BALTIMORE 6714 Ritchie Hwy Glen Burnie, MD 21061 Tel.: (410) 863-0070 Fax: (410) 863-0075 active.baltimore@future.ca</p>	<p>CHERRY HILL 1871 Route 70 East Cherry Hill, NJ 08003 Tel.: (856) 424-7070 Fax: (856) 424-7722 active.cherry.hill@future.ca</p>	<p>DETROIT 29447 Five Mile Road Livonia, MI 48154 Tel.: (734) 525-0153 Fax: (734) 525-1015 active.detroit@future.ca</p>	<p>SEATTLE 13107 Northrup Way Bellevue, WA 98005 Tel.: (425) 881-8191 Fax: (425) 883-6820 active.seattle@future.ca</p>
<p>CAMBRIDGE 73 First Street Cambridge, MA 02141 Tel: (617) 864-3588 Fax: (617) 864-0855 active.cambridge@future.ca</p>	<p>CHICAGO 1776 West Golf Road Mt. Prospect, IL 60056 Tel.: (847) 640-7713 Fax: (847) 640-7613 active.chicago@future.ca</p>	<p>LONG ISLAND 3075 Veterans Mem. Hwy. Ronkonkoma, NY 11779 Tel.: (631) 471-5400 Fax: (631) 471-5410 active.long.island@future.ca</p>	<p>WOBURN 11 Cummings Park Woburn, MA 01801 Tel.: (781) 932-0050 Fax: (781) 933-8884 active.woburn@future.ca</p>

Active has it... When you need it! www.activestores.com